

# KA7500C

## SMPS Controller

### Features

- Internal regulator provides a stable 5V reference supply trimmed to  $\pm 1\%$  Accuracy.
- Uncommitted output TR for 200mA sink or source current
- Output control for push-pull or single-ended operation
- Variable duty cycle by dead time control (pin 4) Complete PWM control circuit
- On-chip oscillator with master or slave operation
- Internal circuit prohibits double pulse at either output

### Description

The KA7500C is used for the control circuit of the pulse width modulation switching regulator. The KA7500C consists of 5V reference voltage circuit, two error amplifiers, flip flop, an output control circuit, a PWM comparator, a dead time comparator and an oscillator. This device can be operated in the switching frequency of 1 KHz to 300 KHz. The precision of voltage reference( $V_{ref}$ ) is improved up to  $\pm 1\%$  with trimming. This provides a better output voltage regulation. The operating temperature range is  $-25^{\circ}\text{C} \sim +85^{\circ}\text{C}$

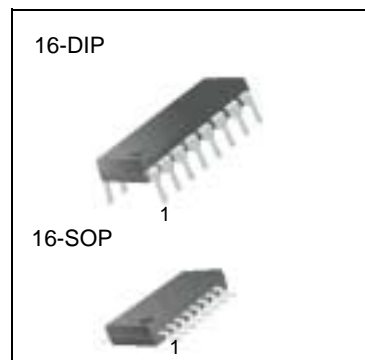

### Internal Block Diagram

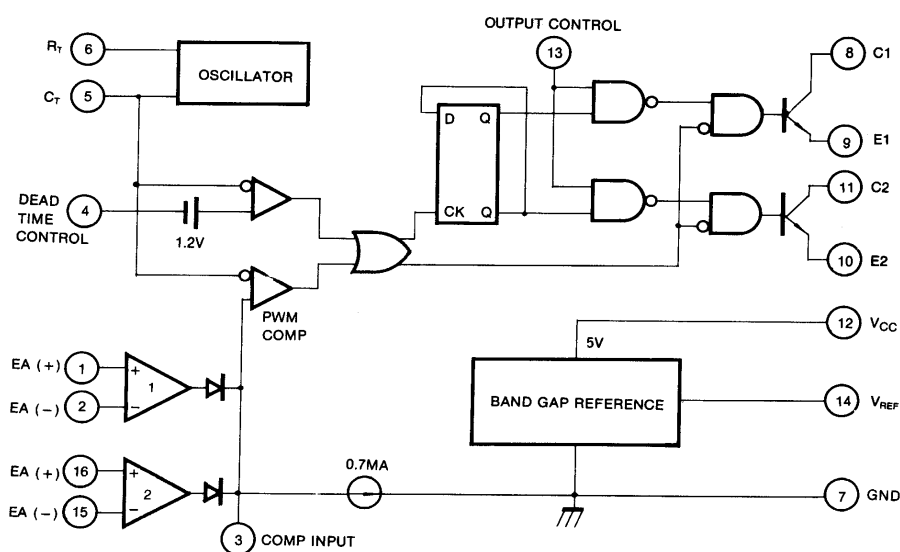

## Absolute Maximum Ratings

Parameter	Symbol	Value	Unit
Supply Voltage	V <sub>CC</sub>	42	V
Collector Supply Voltage	V <sub>C</sub>	42	V
Output Current	I <sub>O</sub>	250	mA
Amplifier Input Voltage	V <sub>IN</sub>	V <sub>CC</sub> + 0.3	V
Power Dissipation (T <sub>A</sub> = 25°C)	P <sub>D</sub>	1 (KA7500C) 0.9 (KA7500CD)	W
Operating Temperature Range	T <sub>OPR</sub>	-25 ~ +85	°C
Storage Temperature Range	T <sub>STG</sub>	-65 ~ +150	°C

## Recommended Operating Conditions

Parameter	Symbol	Min.	Typ.	Max.	Unit
Power Supply Voltage	V <sub>CC</sub>	7.0	15	40	V
Collector Output Voltage	V <sub>C1</sub> , V <sub>C2</sub>	-	30	40	V
Collector Output Current (Each transistor)	I <sub>C1</sub> , I <sub>C2</sub>	-	-	200	mA
Amplifier Input Voltage	V <sub>IN</sub>	0.3	-	V <sub>CC</sub> -2.0	V
Current Into Feedback Terminal	I <sub>fb</sub>	-	-	0.3	mA
Reference Output Current	I <sub>ref</sub>	-	-	10	mA
Timing Resistor	R <sub>T</sub>	1.8	30	500	KΩ
Timing Capacitor	C <sub>T</sub>	0.0047	0.001	10	μF
Oscillator Frequency	f <sub>osc</sub>	1.0	40	200	kHz
PWM Input Voltage (Pins 3, 4, 13)	-	0.3	-	5.3	V

## Electrical Characteristics

( $V_{CC} = 20V$ ,  $f = 10KHz$ ,  $T_A = -25^{\circ}C$  to  $+85^{\circ}C$ , unless otherwise specified)

Parameter	Symbol	Conditions	Min.	Typ.	Max.	Unit
<b>REFERENCE SECTION</b>						
Reference Output Voltage	$V_{REF}$	$I_{REF} = 1mA$ , $T_A = 25^{\circ}C$ (Note1)	4.95	5.0	5.05	V
		$I_{REF} = 1mA$	4.9	5.0	5.1	
Line Regulation	$R_{Line}$	$V_{CC} = 7V$ to $40V$	-	2.0	25	mV
Load Regulation	$R_{LOAD}$	$I_{REF} = 1mA$ to $10mA$	-	1.0	15	mV
Short-Circuit Output Current	$I_{SC}$	$V_{REF} = 0V$	10	35	50	mA
<b>OSCILLATOR SECTION</b>						
Oscillation Frequency	$f_{osc}$	$C_T = 0.001\mu F$ , $R_T = 30K\Omega$	-	40	-	KHz
		$C_T = 0.001\mu F$ , $R_T = 12K\Omega$ , $T_A = 25^{\circ}C$	9.2	10	10.8	
		$C_T = 0.001\mu F$ , $R_T = 30K\Omega$ , $T_A = T_{low}$ to $T_{high}$	9.0	-	12	
Frequency Change with Temperature	$\Delta f/\Delta T$	$C_T = 0.01\mu F$ , $R_T = 12K\Omega$	-	-	2	%
<b>DEAD TIME CONTROL SECTION</b>						
Input Bias Current	$I_{BIAS}$	$V_{CC} = 15V$ , $0V \leq V_4 \leq 5.25V$	-	-2.0	-10	$\mu A$
Maximum Duty Cycle	$D(MAX)$	$V_{CC} = 15V$ , $V_4 = 0V$ O.C Pin = $V_{REF}$	45	-	-	%
Input Threshold Voltage	$V_{ITH}$	Zero Duty Cycle	-	3.0	3.3	V
		Max. Duty Cycle	0	-	-	
<b>ERROR AMP SECTION</b>						
Input Offset Voltage	$V_{IO}$	$V_3 = 2.5V$	-	2.0	10	mV
Input Offset Current	$I_{IO}$	$V_3 = 2.5V$	-	25	250	mA
Input Bias Current	$I_{BIAS}$	$V_3 = 2.5V$	-	0.2	1.0	$\mu A$
Common Mode Input Voltage	$V_{CM}$	$7V \leq V_{CC} \leq 40V$	-0.3	-	$V_{CC}$	V
Open-Loop Voltage Gain	$G_{VO}$	$0.5V \leq V_3 \leq 3.5V$	70	95	-	dB
Unit-Gain Bandwidth	$BW$	-	-	650	-	KHz
<b>PWM COMPARATOR SECTION</b>						
Input Threshold Voltage	$V_{ITH}$	Zero Duty Cycle	-	4	4.5	V
Input Sink Current	$I_{SINK}$	$V_3 = 0.7V$	-0.3	-0.7	-	mA
<b>OUTPUT SECTION</b>						
Output Saturation Voltage Common Emitter	$V_{CE(SAT)}$	$V_E = 0V$ , $I_C = 200mA$	-	1.1	1.3	V

## Electrical Characteristics

( $V_{CC} = 20V$ ,  $f = 10KHz$ ,  $T_A = -25^{\circ}C$  to  $+85^{\circ}C$ , unless otherwise specified)

Parameter	Symbol	Conditions	Min.	Typ.	Max.	Unit
Emitter-Follower	$V_{CC(SAT)}$	$V_C = 15V$ , $I_E = -200mA$	-	1.5	2.5	V
Collector Off-State Current	$I_{C(OFF)}$	$V_{CC} = 40V$ , $V_{CE} = 40V$	-	2	100	$\mu A$
Emitter Off-State Current	$I_{E(OFF)}$	$V_{CC} = V_C = 40V$ , $V_E = 0V$	-	-	-100	
<b>TOTAL DEVICE</b>						
Supply Current	$I_{CC}$	Pin 6 = $V_{REF}$ , $V_{CC} = 15V$	-	6	10	mA
<b>OUTPUT SWITCHING CHARACTERISTIC</b>						
Rise Time	tR	-	-	100	200	ns
Common Emitter, Common Collector						
Fall Time	tF	-	-	25	100	ns
Common Emitter, Common Collector						

### Note :

1. This is guaranteed where the marking code of the package surface is over 027

## Typical Application

### Pulse Width Modulated Step-down Converter

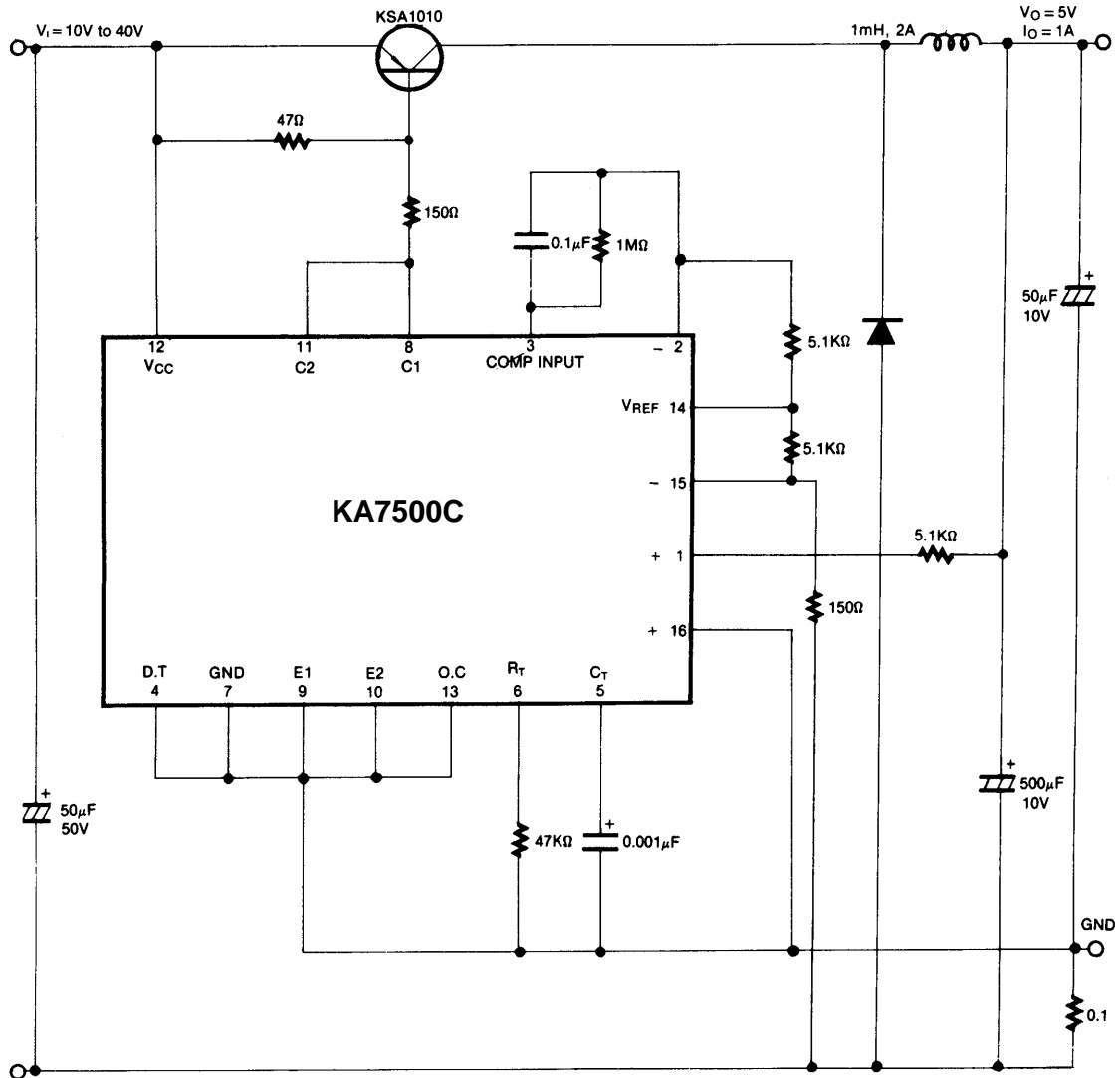



**Mechanical Dimensions** (Continued)

**Package**

Dimensions in millimeters

**16-DIP**

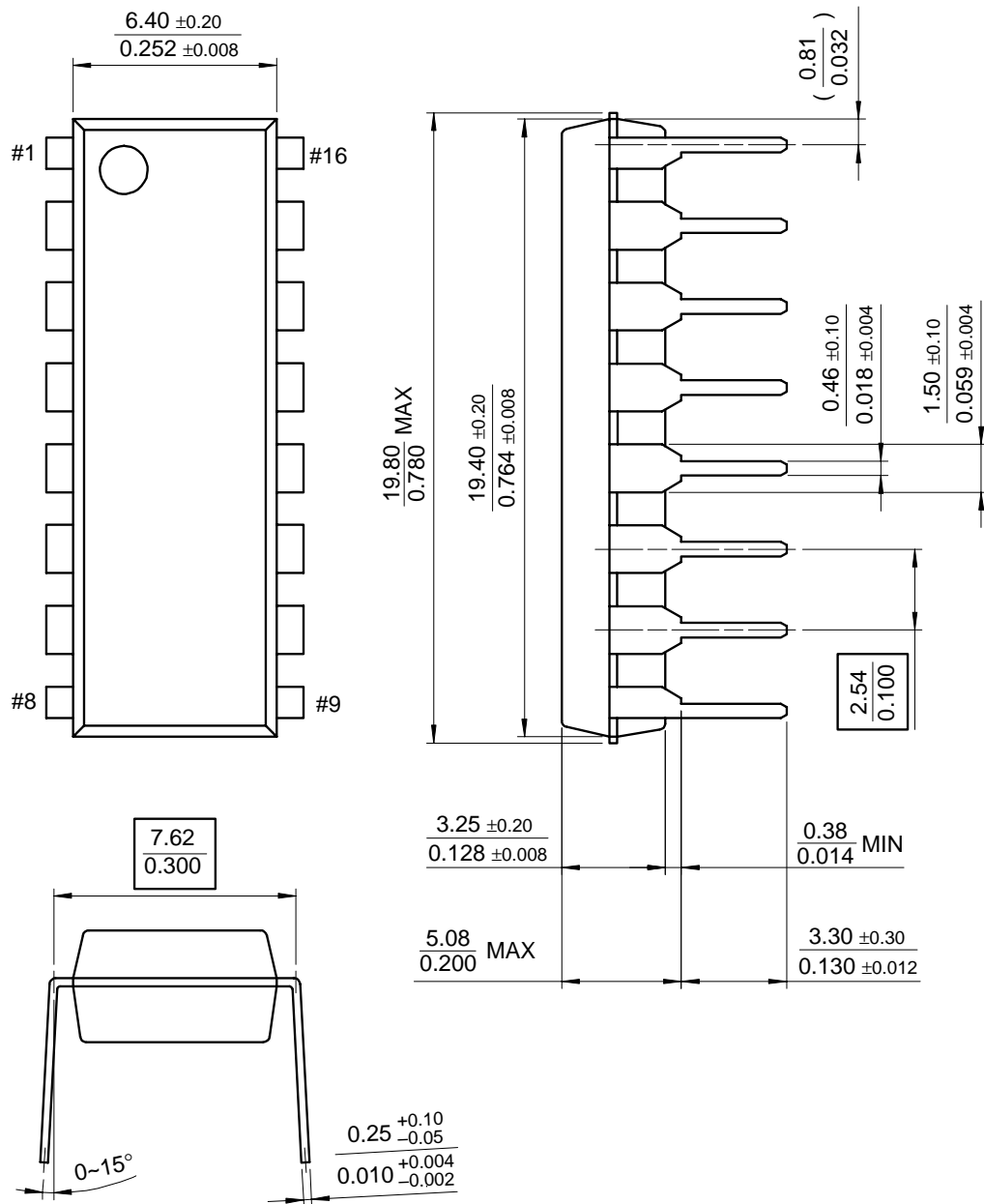

## Ordering Information

Product Number	Package	Operating Temperature
KA7500C	16-DIP	-25 ~ + 85°C
KA7500CD	16-SOP	



**DISCLAIMER**

FAIRCHILD SEMICONDUCTOR RESERVES THE RIGHT TO MAKE CHANGES WITHOUT FURTHER NOTICE TO ANY PRODUCTS HEREIN TO IMPROVE RELIABILITY, FUNCTION OR DESIGN. FAIRCHILD DOES NOT ASSUME ANY LIABILITY ARISING OUT OF THE APPLICATION OR USE OF ANY PRODUCT OR CIRCUIT DESCRIBED HEREIN; NEITHER DOES IT CONVEY ANY LICENSE UNDER ITS PATENT RIGHTS, NOR THE RIGHTS OF OTHERS.

**LIFE SUPPORT POLICY**

FAIRCHILD'S PRODUCTS ARE NOT AUTHORIZED FOR USE AS CRITICAL COMPONENTS IN LIFE SUPPORT DEVICES OR SYSTEMS WITHOUT THE EXPRESS WRITTEN APPROVAL OF THE PRESIDENT OF FAIRCHILD SEMICONDUCTOR INTERNATIONAL. As used herein:

1. Life support devices or systems are devices or systems which, (a) are intended for surgical implant into the body, or (b) support or sustain life, and (c) whose failure to perform when properly used in accordance with instructions for use provided in the labeling, can be reasonably expected to result in a significant injury of the user.
2. A critical component in any component of a life support device or system whose failure to perform can be reasonably expected to cause the failure of the life support device or system, or to affect its safety or effectiveness.